



# BD30005

## 30W DUAL DC/DC CONVERTER

22-26V<sub>IN</sub>, 3.3V<sub>OUT</sub> & 1.8V<sub>OUT</sub>

### Key Features

- 85% Efficiency
- Input-to-output isolation
- Input LC filter
- Soft start
- Short circuit protection
- 150µA off state current
- Multiple converter synchronization
- Independently adjustable outputs
- Six-sided EMI shielding



### Functional Description

The BD30005 is a 30W Dual DC/DC Converter with an input voltage range of 22V<sub>IN</sub> to 26V<sub>IN</sub> and provides an output of 3.3V<sub>OUT</sub>@4.5A and 1.8V<sub>OUT</sub>@3.0A. It features a 400kHz switching frequency, forward topology and comes packaged in a 2x2x0.395-inch case with an industry standard pin out arrangement. Synchronous rectification improves efficiency, while the dual independent control loop, independent output voltage adjustability, and internal frequency synchronization offer design flexibility. The six-sided shielding SMD and improved thermal techniques enhance reliability.

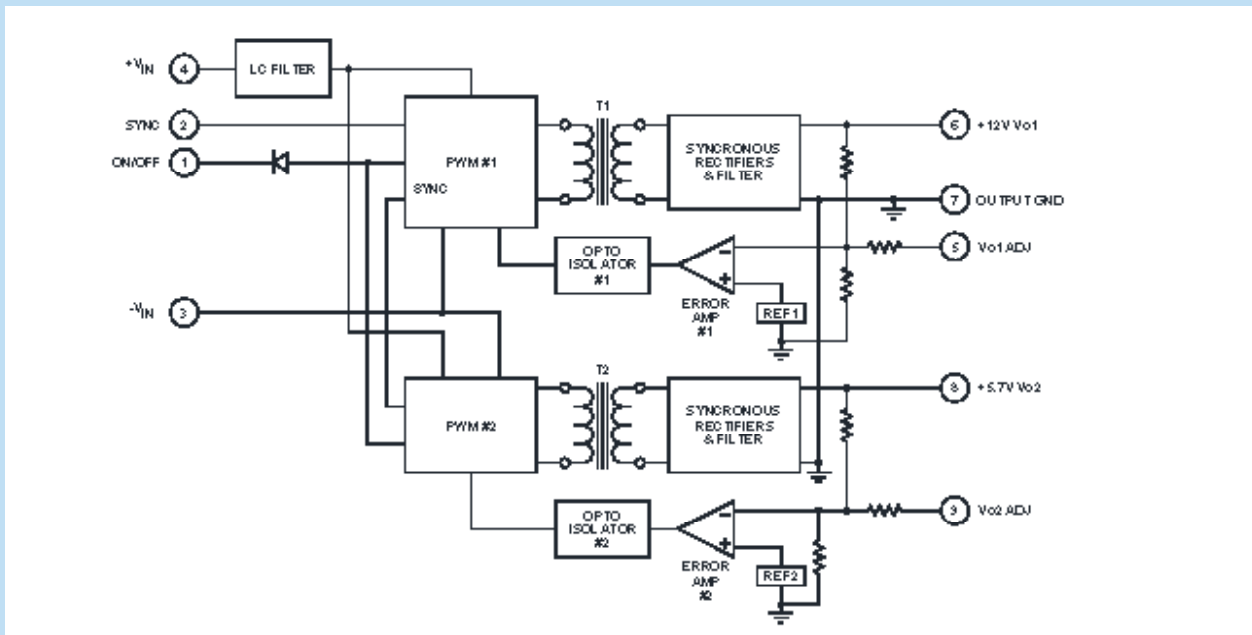

Typical Block Diagram of BD30005 (Dual Output)

## Electrical Specifications

### INPUT SPECIFICATIONS

Unless otherwise specified, all parameters are given under typical +25°C with nominal input voltage and under full output load conditions.

PARAMETER	CONDITION / NOTE	MIN	TYP	MAX	UNIT
Input Voltage Range		22	24	26	Vdc
Input Filter	LC				
Reverse Polarity	External series-blocking diode				
No Load Input Current			1006		mA
Full Load Input Current			38		mA
Input Reflected Ripple*					
Input Surge Current (20µS Spike)				10	A
Short Circuit Current Limit				150	% I <sub>IN</sub>
Undervoltage Shutdown			8		Vdc
Turn On Delay	Including Soft Start		4		mS
Off State Current				150	µA
Remote ON/OFF Control					
Supply ON	Pin 1 Open (Open circuit voltage: 12V Max.)				
Supply OFF		0		0.8	Vdc
Logic Input Reference	-Input				
Logic Compatibility	TTL Open Collector or CMOS Open Drain				
Converter Standby Input Current	No Load				

\* Input reflected ripple is measured with a 100µF capacitor placed across the input power pins.

### OUTPUT SPECIFICATIONS

PARAMETER	CONDITION / NOTE	MIN	TYP	MAX	UNIT
Voltage and Current Ratings					
V <sub>O1</sub> (Pin 6 - 7)			3.3		Vdc
I <sub>O1</sub>			4500		mA
V <sub>O2</sub> (Pin 8-7)			1.8		Vdc
I <sub>O2</sub>			3000		mA
Output Voltage Accuracy			±1	±2	%
Output Voltage Adjustment	Per output	±3	±5		%
Ripple & Noise	(See App. Note DC-003)		75	100	mV <sub>PP</sub>
Line Regulation			±0.5	±1	%
Load Regulation			±1		%
Temperature Coefficient @ FL			0.02		%/°C
Transient Response Time	50% FL to FL to 50% FL		100	150	µS
Short Circuit Protection	All outputs, by input current limiting				

### GENERAL SPECIFICATIONS

PARAMETER	CONDITION / NOTE	MIN	TYP	MAX	UNIT
Efficiency (at full power)			85		%
Isolation Voltage (1 min.)			1500		Vdc
Isolation Resistance			10 <sup>9</sup>		Ω
Isolation Capacitance			1000		pF
Switching Frequency			400		kHz

### ENVIRONMENTAL SPECIFICATIONS

PARAMETER	CONDITION / NOTE	MIN	TYP	MAX	UNIT
Operating Temperature, Industrial (Ambient)		-40		+85	°C
Storage Temperature Range		-55		+125	°C
Thermal Resistance			5	6	°C/W <sub>DISS</sub>
Humidity	Up to 95% non-condensing				
Cooling	Free-air convection				
EMI/RFI	Six-sided continuous shielded metal case				
MTBF	per MIL-HNBK-217F (Ground benign, +25°C)		700,000		hours

## PHYSICAL CHARACTERISTICS

PARAMETER	CONDITION / NOTE	MIN	TYP	MAX	UNIT
Dimensions (L×W×H)	2.00×2.00×0.395 in. (50.80×50.80×10.03mm)				
Weight	2.43 oz. (69g)				
Case Material	Coated metal				
Shielding Connection	-V <sub>IN</sub> (Pin 3)				

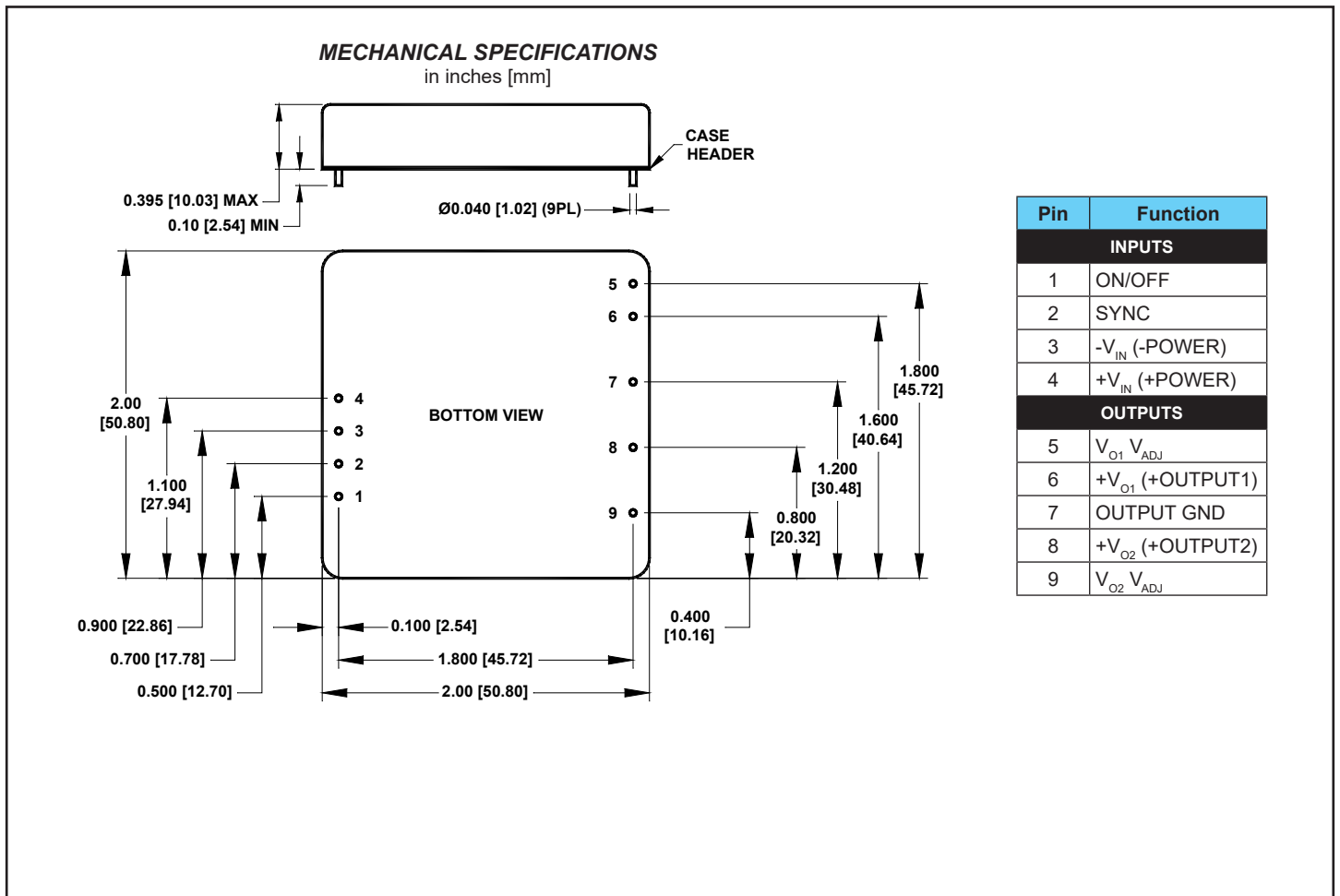
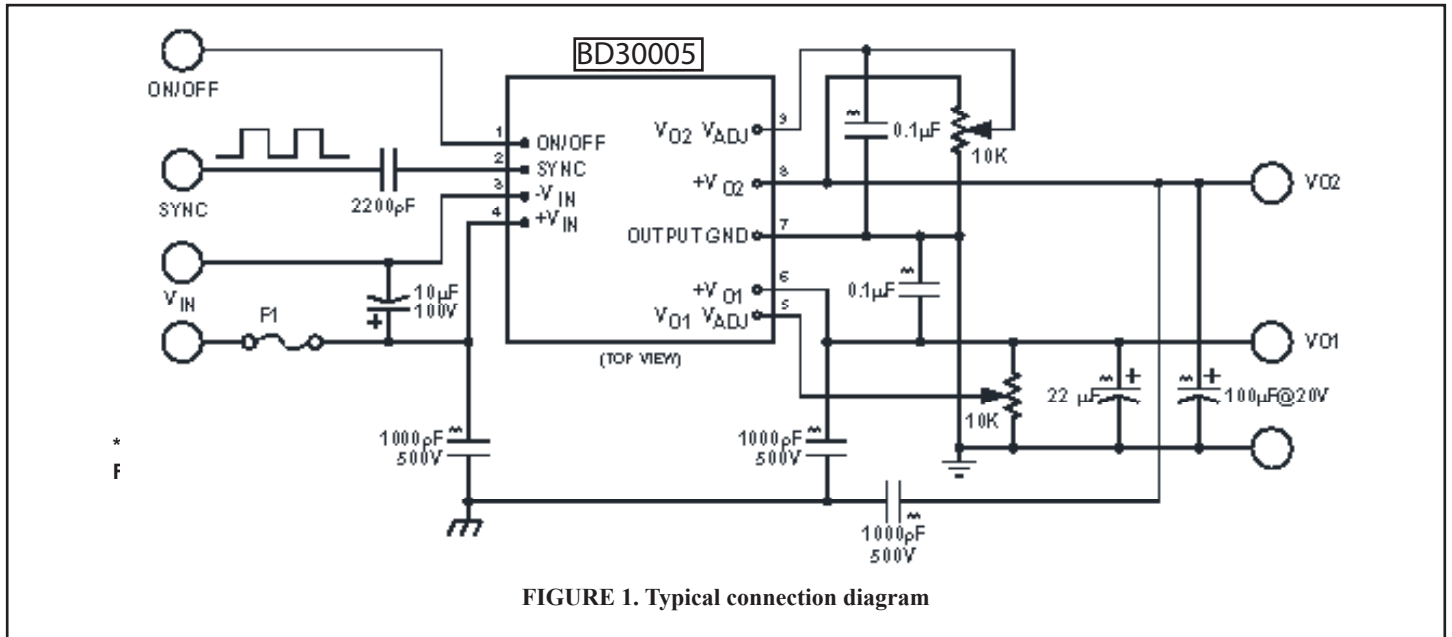

### **EXTERNAL SYNCHRONIZATION**

The converter can be synchronized to an external TTL or CMOS clock signal. Insert a 470pF to 1000pF ceramic capacitor between the driving clock signal and the Sync pin (Pin 2) of the

converter. The frequency of the signal must be between 370kHz to 450kHz and the duty cycle 20% high and 80% low. See application note DC-005: Synchronization.

---

### **EXTERNAL TRIMMING OF OUTPUT VOLTAGES**

To trim the output voltage DOWN, connect a 5%, 1/4W resistor between the + (plus) output and trim pins of the converter. To trim the output voltage UP, connect a 5%, 1/4W resistor between the – (minus) output and trim pin of the converter. For UP/DOWN trimming capability, connect a 10k $\Omega$  potentiometer between the + and – pins, with the wiper arm connected to the trim pin. The trim resistors/potentiometer can be connected at the converter output pins or the load. However, if connected at the load, the resistance of the runs becomes part of the feedback network, improving load

regulation. If the load is some distance from the converter, the use of #20 gauge wire is recommended to avoid excessive voltage drop due to the resistance of the circuit paths.

See our application notes:

DC-001: Testing Transient Response in DC/DC Converters

DC-004: Thermal Consideration for DC/DC Converters

DC-006: Synchronous Rectification