



BD30001

25W SINGLE DC/DC CONVERTER

4:1 Input

Key Features

- 4:1 input voltage range
- 77% efficiency
- Input-to-output isolation
- Input LC filter
- Soft start
- Short circuit protection
- 150 μ A off state current
- Multiple converter synchronization
- Independently adjustable outputs
- Six-sided EMI shielding

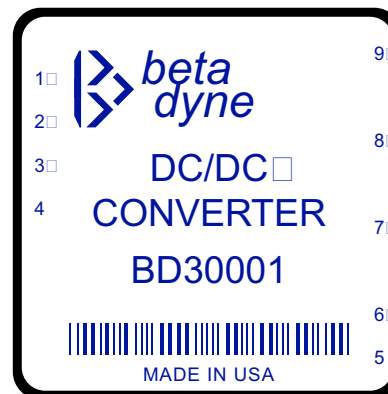

Functional Description

The BD30001 is a single 25W DC/DC converter designed to operate from 9–36V_{IN} and provide 5V_{OUT} @ 5A minimum. It offers 4:1 input voltage range, 400kHz switching frequency, forward topology and is packaged in a 2×2×0.395-inch case with an industry standard pin out arrangement. Synchronous rectification improves efficiency, while the six-sided shielding SMD and improved thermal techniques enhance reliability.

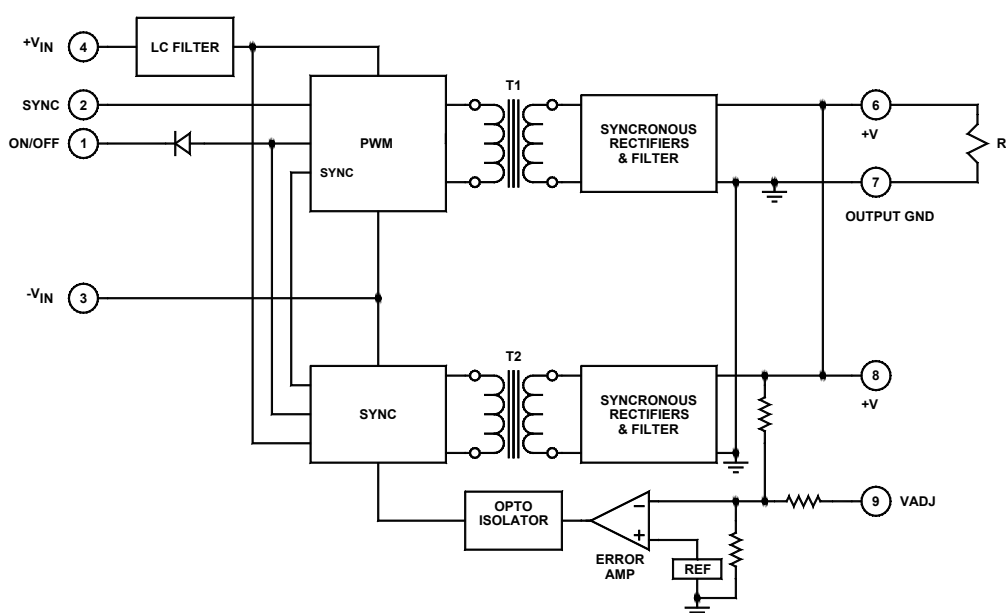

Typical Block Diagram

Electrical Specifications

INPUT SPECIFICATIONS

Unless otherwise specified, all parameters are given under typical +25°C with nominal input voltage and under full output load conditions.

PARAMETER	CONDITION / NOTE	MIN	TYP	MAX	UNIT
Input Voltage Range	See Table 1	9	24	36	Vdc
Input Filter	LC				
Reverse Polarity	External series-blocking diode				
No Load Input Current			70		mA
Full Load Input Current			1352		mA
Input Reflected Ripple ¹					
Input Surge Current (20µS Spike)				10	A
Short Circuit Current Limit				150	% I _{IN}
Undervoltage Shutdown			8		Vdc
Turn On Delay	Including Soft Start		4		mS
Off State Current				150	µA
Remote ON/OFF Control					
Supply ON	Pin 1 Open (Open circuit voltage: 12V Max.)				
Supply OFF		0		0.8	Vdc
Logic Input Reference	-Input				
Logic Compatibility	TTL Open Collector or CMOS Open Drain				
Converter Standby Input Current	No Load				

OUTPUT SPECIFICATIONS

PARAMETER	CONDITION / NOTE	MIN	TYP	MAX	UNIT
Voltage			5		Vdc
Output Voltage Accuracy			±1	±2	%
Output Voltage Adjustment	Per output	±3	±5		%
Output Current			5000		mA
Ripple & Noise	(See App. Note DC-003)		75	100	mV _{PP}
Line Regulation			±0.5	±1	%
Load Regulation			±1		%
Temperature Coefficient @ FL			0.02		%/°C
Transient Response Time	50% FL to FL to 50% FL		100	150	µS
Short Circuit Protection	All outputs, by input current limiting				

GENERAL SPECIFICATIONS

PARAMETER	CONDITION / NOTE	MIN	TYP	MAX	UNIT
Efficiency (at full power)					
Isolation Voltage (1 min.)					
Isolation Resistance			9		Ω
Isolation Capacitance					
Switching Frequency					

ENVIRONMENTAL SPECIFICATIONS

PARAMETER	CONDITION / NOTE	MIN	TYP	MAX	UNIT
Operating Temperature, Industrial (Ambient)		-40		+71	°C
Operating Temperature, Extended	Insert an x after model number	-55		+85	°C
Storage Temperature Range		-55		+125	°C
Thermal Resistance			5	6	°C/W _{DISS}
Derating	See Figure 2				
Humidity	Up to 95% non-condensing				
Cooling	Free-air convection				
EMI/RFI	Six-sided continuous shielded metal case				
MTBF	per MIL-HNBK-217F (Ground benign, +25°C)		700,000		hours

PHYSICAL CHARACTERISTICS

PARAMETER	CONDITION / NOTE	MIN	TYP	MAX	UNIT
Dimensions (L×W×H)	2.00×2.00×0.395 in. (50.80×50.80×10.03mm)				
Weight	2 oz. (58g)				
Case Material	Coated metal				
Shielding Connection, 24V _{IN}	-V _{IN} (Pin 3)				

¹ Input reflected ripple is measured with a 100µF capacitor placed across the input power pins.

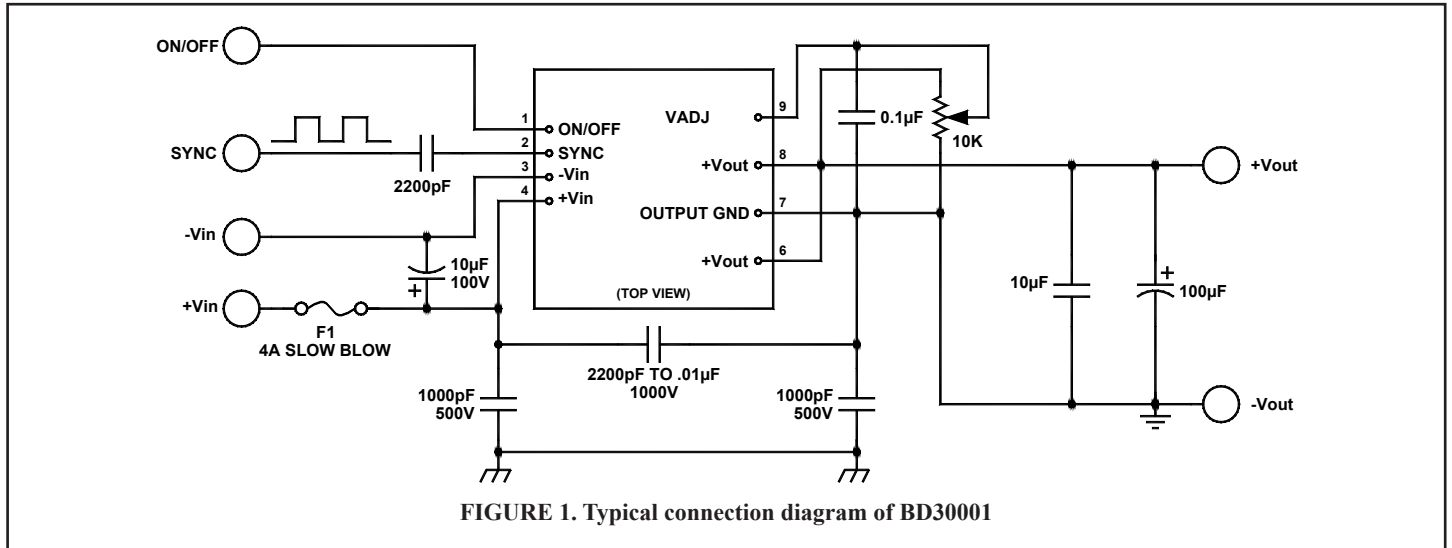
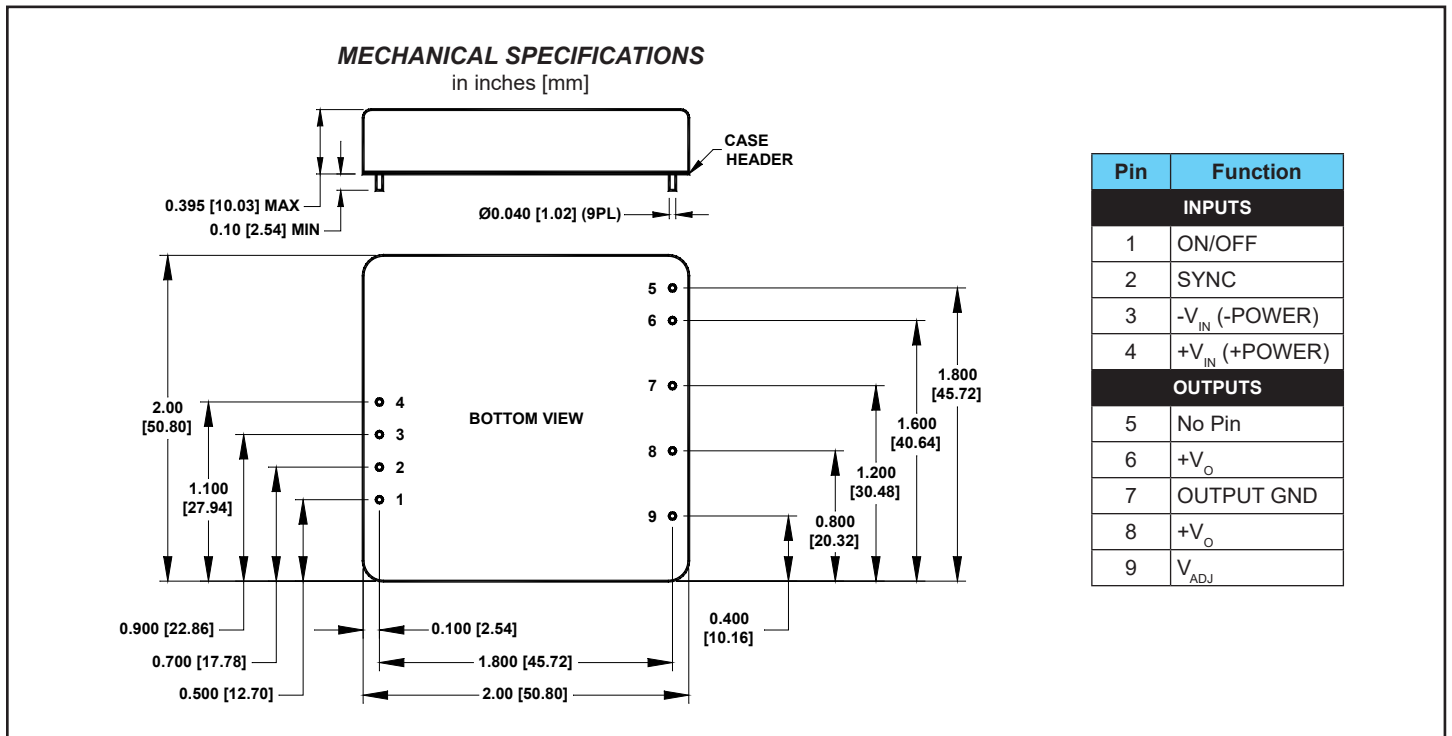

FIGURE 1. Typical connection diagram of BD30001



EXTERNAL SYNCHRONIZATION

The converter can be synchronized to an external TTL or CMOS clock signal. Insert a 470pF to 1000pF ceramic capacitor between the driving clock signal and the Sync pin (Pin 2) of the

converter. The frequency of the signal must be between 370kHz to 450kHz and the duty cycle 20% high and 80% low. See application note DC-005: Synchronization.

EXTERNAL TRIMMING OF OUTPUT VOLTAGES

To trim the output voltage DOWN, connect a 5%, 1/4W resistor between the + (plus) output and trim pins of the converter. To trim the output voltage UP, connect a 5%, 1/4W resistor between the – (minus) output and trim pin of the converter. For UP/DOWN trimming capability, connect a 10kΩ potentiometer between the + and – pins, with the wiper arm connected to the trim pin. The trim resistors/potentiometer can be connected at the converter output pins or the load. However, if connected at the load, the resistance of the runs becomes part of the feedback network, improving load

regulation. If the load is some distance from the converter, the use of #20 gauge wire is recommended to avoid excessive voltage drop due to the resistance of the circuit paths.

See our application notes:

- DC-001: Testing Transient Response in DC/DC Converters
- DC-004: Thermal Consideration for DC/DC Converters
- DC-006: Synchronous Rectification

TABLE 1. Minimum input operating voltage range for 24V_{IN}

BD30001	
% FL	Minimum Input Operating Voltage 24V _{IN}
10	7.0
25	8.5
50	8.8
75	9.0
100	9.5

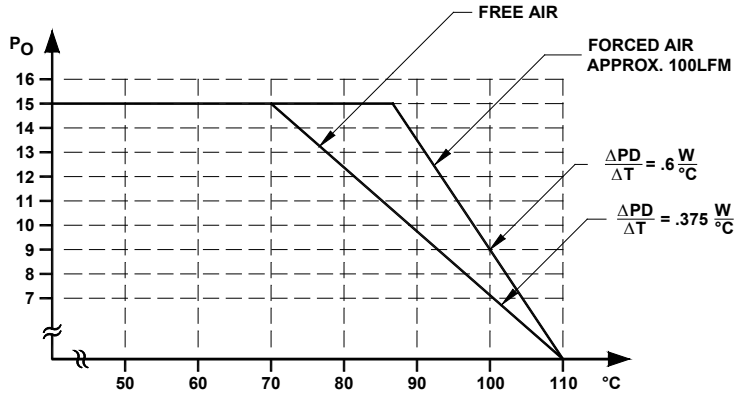

FIGURE 2. Worst case derating of BD30001