



BD25005

25W DUAL DC/DC CONVERTER

2000Vdc Isolation
US Patent 6,262,901 B1

Key Features

- 50 μ S transient response
- 81% efficiency
- Six-sided shielding
- Soft start
- Dual output
- Adjustable output
- Short circuit protection
- 75 μ A off state current
- Wide input voltage range (2:1)
- Synchronization
- Industry pinout

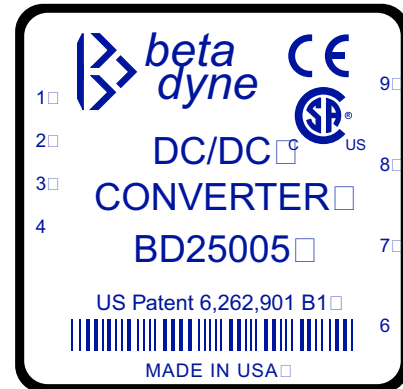

Functional Description

The BD25005 is a 25W dual DC/DC converter that accepts 24V_{IN}, produces ± 15 V_{OUT} and is tested for 2000Vdc isolation. State-of-the-art design and packaging techniques make possible the 20W/in³ power density without sacrificing functionality or performance.

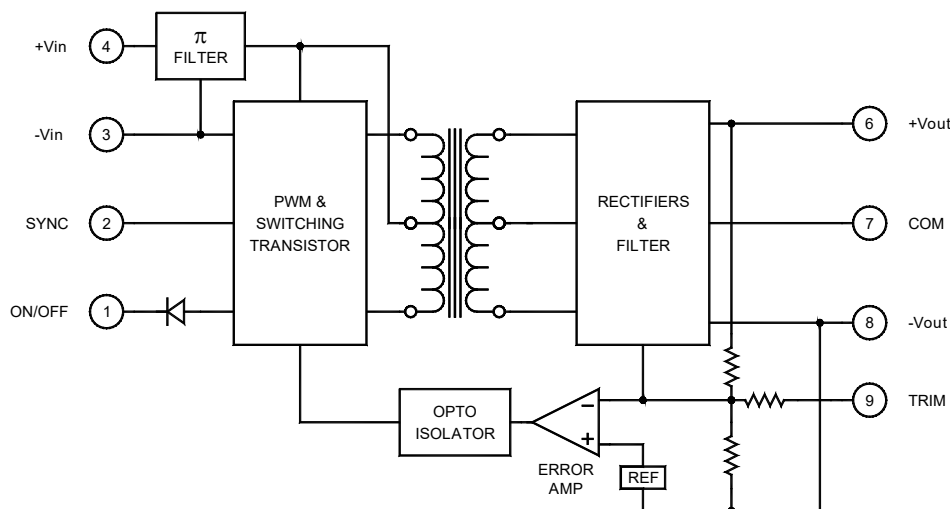

Typical Block Diagram

Electrical Specifications

INPUT SPECIFICATIONS

Unless otherwise specified, all parameters are given under typical +25°C with nominal input voltage and under full output load conditions.

PARAMETER	CONDITION / NOTE	MIN	TYP	MAX	UNIT
Input Voltage Range		18	24	36	Vdc
No Load Input Current			40		mA
Full Load Input Current			1210		mA
Reflected Ripple			40		mA _{PP}
Input Filter	LC				
Reverse Polarity Input Current Δ	External series-blocking diode			12	A
Input Surge Current (20 μ S Spike)				10	A
Short Circuit Current Limit			150		% I _{IN}
Undervoltage Shutdown			8		Vdc
Off State Current			75		μ A
Remote ON/OFF Control					
Supply ON	Open (Open circuit voltage: 12V Max.)				
Supply OFF		0		0.8	Vdc
Logic Input Reference	-Input				
Logic Compatibility	TTL Open Collector or CMOS Open Drain				
Converter Standby Current			32		mA

OUTPUT SPECIFICATIONS

PARAMETER	CONDITION / NOTE	MIN	TYP	MAX	UNIT
Output Voltage			± 15		Vdc
Output Voltage Accuracy			± 1		%
Output Current			± 830		mA
Output Voltage Adjustment			3	± 5	%
Voltage Balance	Balanced loads		± 1	± 2	%
Minimum Load		10			% of FL
Ripple & Noise	(See App. Note DC-003)		1	2	%V _{PP} of V _{OUT}
Line Regulation	Minimum V _{IN} to maximum V _{IN}		± 1	2	%
Load Regulation					
Load Regulation	Balanced loads		± 1		%
Temperature Coefficient @ FL			0.02		%/°C
Transient Response Time	50% FL to FL to 50% FL		50		μ S
Short Circuit Protection	All outputs, by input current limiting				
Output Short Circuit Duration	Continuous				

GENERAL SPECIFICATIONS

PARAMETER	CONDITION / NOTE	MIN	TYP	MAX	UNIT
Efficiency			81		%
Isolation Voltage (1 min.)	100% Tested in production	2000			Vdc
Isolation Resistance			10 ⁹		Ω
Isolation Capacitance			80		pF
Switching Frequency			160		kHz

ENVIRONMENTAL SPECIFICATIONS

PARAMETER	CONDITION / NOTE	MIN	TYP	MAX	UNIT
Operating Temperature, Industrial (Ambient)*	See Figure 2	-40		+71	°C
Operating Temperature, Extended	(Please contact factory)				
Storage Temperature Range		-55		+125	°C
Thermal Resistance					°C/W _{DISS}
Maximum Operating Case Temperature				105	°C
Thermal Turn Off, Case Temperature		95	100	115	°C
Thermal Hysteresis		5	10		°C
Derating	See Figure 2				
Humidity	Up to 95% non-condensing				
Cooling	Free-air convection				
EMI/RFI	Six-sided continuous shielded metal case				
MJBF *See footnotes 2, 3, 4 and 5	per MIL-HNBK-217F (Ground benign, +25°C)		718,000		hours

PHYSICAL CHARACTERISTICS

PARAMETER	CONDITION / NOTE	MIN	TYP	MAX	UNIT
Dimensions (L×W×H)	2.00×2.00×0.395 in. (50.80×50.80×10.03mm)				
Weight	2 oz. (58g)				
Case Material	Coated metal				
Shielding Connection	-Input (Pin 3)				

¹ **WARNING** - Usage of input fuse with adequate ratings is essential to avoid possible hazard and damage of the unit. A suppressor diode with adequate ratings is intended to be connected in series to the supply for reverse polarity protection.

² Contact factory for -55° to +85°C operating temperature range.

³ The maximum input current at any given input range measured at minimum input voltage is given as $1.6 \cdot I_{\text{NOMINAL}}$. Nominal input current is the typical value measured at the input of the converter under full-load room temperature and nominal input voltage (12, 24 and 48Vin).

⁴ Adequate insulation is to be provided to the converters at the end usage as per applicable requirements.

⁵ Temperature rise on the case of the converters is to be considered during the end usage as per applicable requirements.

EXTERNAL SYNCHRONIZATION

The converter can be synchronized to an external clock by driving the SYNC pin (pin 2) directly or with an open collector-open drain (1 TTL load). The driving signal frequency must be 380kHz ±5% (20% low, 80% high duty cycle). The PWM used in the 25W

series offers bidirectional SYNC ports, which allow multiple unit synchronization by connecting all SYNC pins together. In the absence of an external clock, the faster unit takes control of the SYNC bus and the rest of the units follow.

EXTERNAL TRIMMING OF OUTPUT VOLTAGES

To trim the output voltage DOWN, connect a 5% ¼W resistor between the + (plus) output and trim pins of the converter. To trim the output voltage UP, connect a 5% ¼W resistor between the – (minus) output and trim pin of the converter. For UP/DOWN trimming capability, connect a 10kΩ potentiometer between the + and – pins, with the wiper arm connected to the trim pin. The trim resistors/potentiometer can be connected at the converter output pins or the load. However, if connected at the load, the resistance

of the runs becomes part of the feedback network, improving load regulation. If the load is some distance from the converter, the use of #20 gauge wire is recommended to avoid excessive voltage drop due to the resistance of the circuit paths.

See our application notes:

DC-001: Testing Transient Response in DC/DC Converters

DC-004: Thermal Consideration for DC/DC Converters

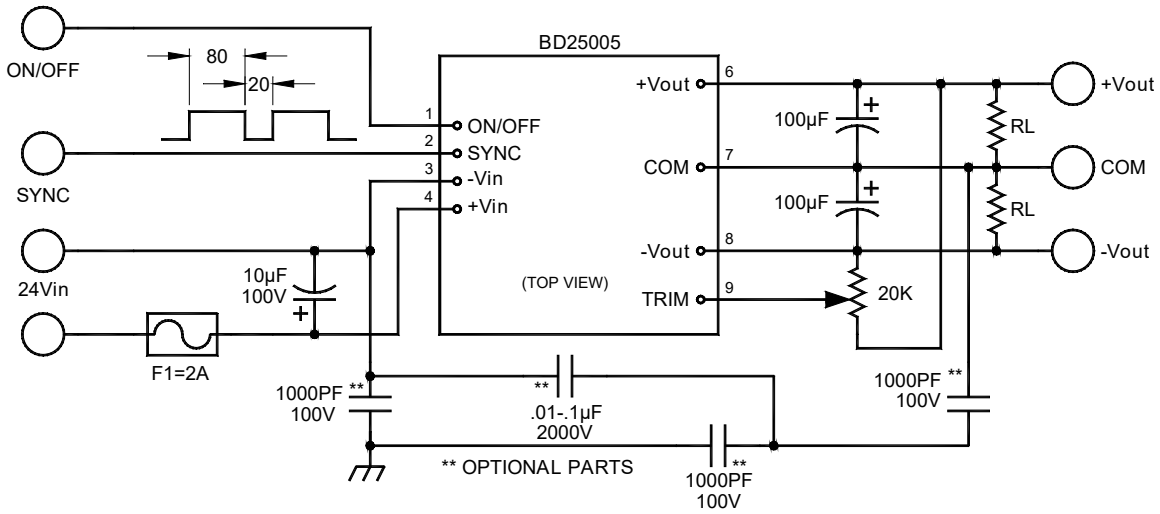

FIGURE 1. Typical connection diagram

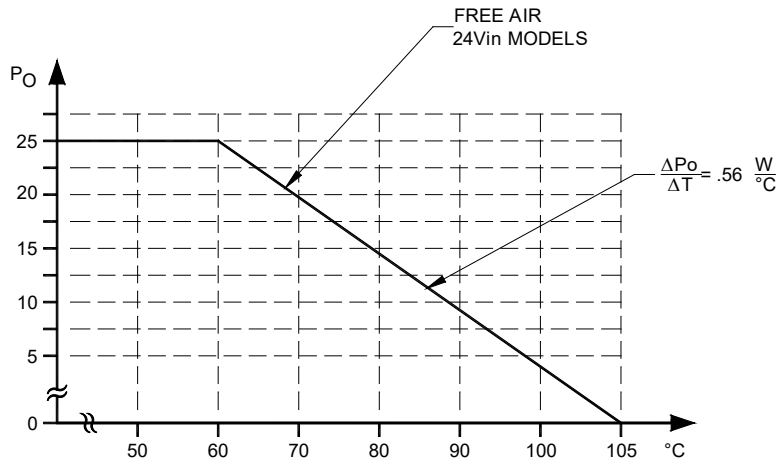
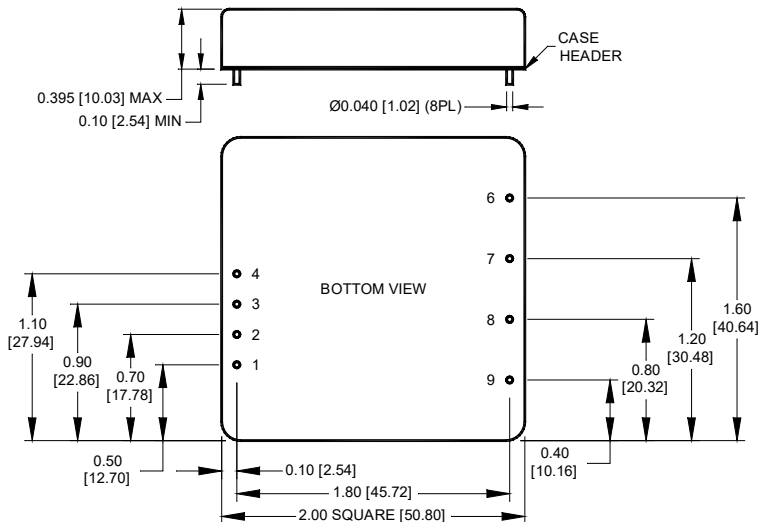

FIGURE 2. Typical derating curves

MECHANICAL SPECIFICATIONS
in inches [mm]



Pin	FUNCTION
	DUAL
1	ON/OFF
2	SYNC
3	-V _{IN}
4	+V _{IN}
5	No Pin
6	+V _{OUT}
7	GND
8	-V _{OUT}
9	V _{OUT} ADJ