



BD16000

15W Low-Noise 4-Output DC/DC Converter

18–36V_{IN}
 3.3V_{OUT}@1A, 5V_{OUT}@1.5A,
 12V_{OUT}@200mA, -5V_{OUT}@250mA

Key Features

- 2:1 input voltage range
- Four low-noise outputs
- Input-to-output isolation
- Soft start
- Input Pi filter
- Short circuit protection
- Six-sided EMI shielding

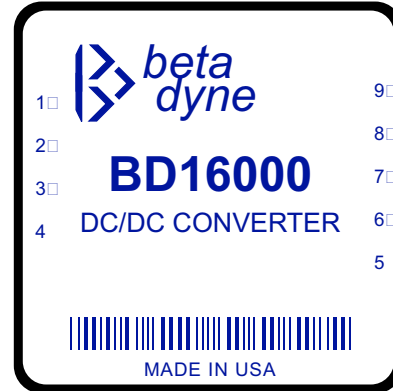

Functional Description

The BD16000 is a low-noise, four-output, isolated DC/DC converter that accepts 18–36V_{IN} and provides 3.3V_{OUT}@1A, 5V_{OUT}@1.5A, 12V_{OUT}@200mA, and -5V_{OUT}@250mA. The converter features 380kHz switching frequency, flyback topology and four low-dropout linear regulators to minimize output noise. The converter can be synchronized to a system clock with a 15nS to 150nS pulse. Six-sided shielding, soft start, undervoltage protection and 2:1 input voltage range are standard features.

CONTACT FACTORY FOR OTHER INPUT & OUTPUT VOLTAGE COMBINATIONS

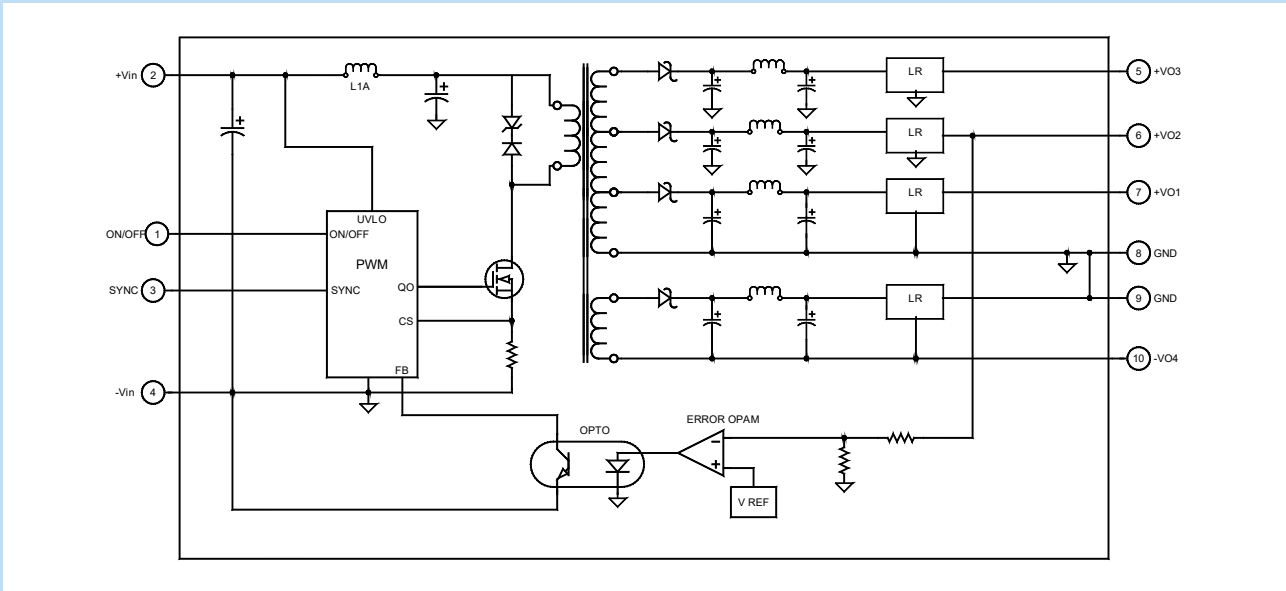

Typical Block Diagram

Unless otherwise specified, all parameters are given under typical +25°C with nominal input voltage and under full output load conditions.

Electrical Specifications

INPUT SPECIFICATIONS

PARAMETER	CONDITION / NOTE	MIN	TYP	MAX	UNIT
Input Voltage Range		18	24	36	Vdc
No Load Input Current	@12Vdc		40		mA
Full Load Input Current	@12Vdc		848		mA
Input Filter	Pi				
Reflected Ripple Current	Measured with 100μF input capacitor		100		mA _{PP}
Reverse Voltage Protection	Parallel Diode		5		A
On/Off	Reference to -V _{IN}				
Converter ON	Pin 1 open				
Converter OFF	Pin 1 shorted to Pin 4				
Pin 1 Open Voltage	Open		10		Vdc
Turn On Delay	Including soft start, See Figure 4		10		mS
Startup Input Voltage		17			Vdc

OUTPUT SPECIFICATIONS

PARAMETER	CONDITION / NOTE	MIN	TYP	MAX	UNIT
Output Voltage	Pin 7 to Pins 8 & 9		3.3		Vdc
Output Voltage Accuracy			0.5	1	%
Output Current			1		A
Ripple & Noise (20MHz BW)			0.5	1	% of V _{OUTFP}
Line Regulation	Outputs fully loaded		0.5	1	%
Load Regulation	10% FL to FL		0.5	1	%
Output Voltage	Pin 6 to Pins 8 & 9		5		Vdc
Output Voltage Accuracy			0.5	1	%
Output Current			1.5		A
Ripple & Noise (20MHz BW)			0.5	1	% of V _{OUTFP}
Line Regulation	Outputs fully loaded		0.5	1	%
Load Regulation	10% FL to FL, Main fully loaded		0.5	1	%
Output Voltage	Pin 5 to Pins 8 & 9		12		Vdc
Output Voltage Accuracy			0.5	1	%
Output Current			200		mA
Ripple & Noise (20MHz BW)			0.2	0.5	% of V _{OUTFP}
Line Regulation	Outputs fully loaded		0.5	1	%
Load Regulation			0.5	1	%
Output Voltage	Pin 10 to Pins 8 & 9		-5		Vdc
Output Voltage Accuracy			0.5	1	%
Output Current			250		mA
Ripple & Noise (20MHz BW)			0.5	1	% of V _{OUTFP}
Line Regulation			0.5	1	%
Load Regulation	Outputs fully loaded		0.5	1	%

ENVIRONMENTAL SPECIFICATIONS

PARAMETER	CONDITION / NOTE	MIN	TYP	MAX	UNIT
Operating Temperature Range (Ambient)		-25		+60	°C
Storage Temperature Range		-60		+125	°C
Derating					
Humidity	Up to 95% non-condensing				
Cooling	Free-air convection				
MTBF	per MIL-HNBK-217F (Ground benign, +25°C)		830,000		hours

GENERAL SPECIFICATIONS

PARAMETER	CONDITION / NOTE	MIN	TYP	MAX	UNIT
Efficiency			71		%
Isolation Voltage (1 min.)		500	1000		Vdc
Isolation Resistance			10 ⁹		Ω
Isolation Capacitance			300		pF
Switching Frequency		360	380	390	kHz
Temperature Coefficient @ FL			±0.02		%/°C
Short Circuit Protection	Input current limit				
Short Circuit Restart	Automatic				

PHYSICAL CHARACTERISTICS

PARAMETER	CONDITION / NOTE	MIN	TYP	MAX	UNIT
Dimensions (L×W×H)	2.00×2.00×0.395 in. (50.80×50.80×10.03mm)				
Weight	2 oz. (58g)				
Case Material	Coated metal				
Shielding	Six-sided continuous				
Case Connection	IN				

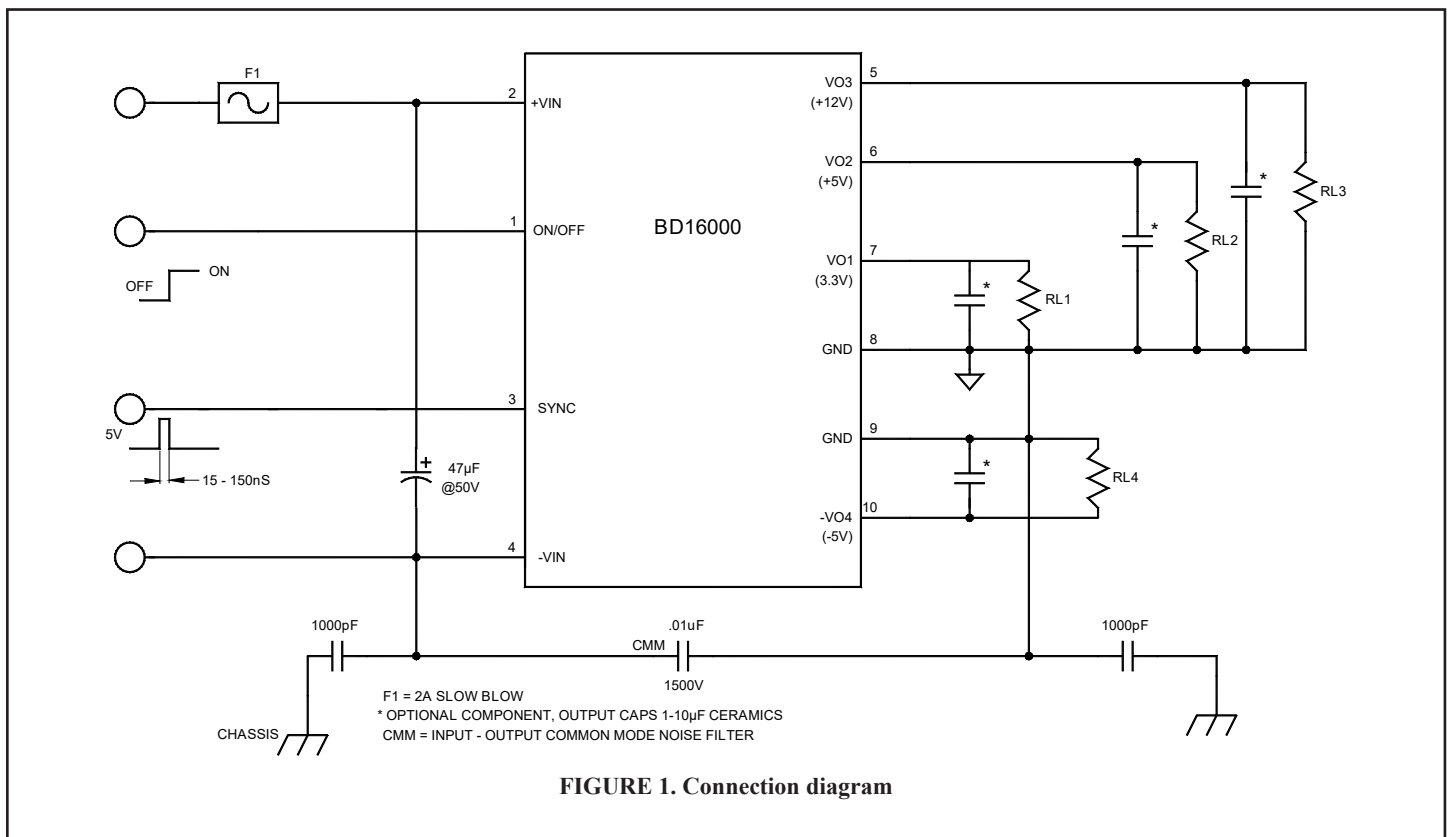

EXTERNAL SYNCHRONIZATION

The converter can be synchronized to an external clock. The external clock MUST have a higher frequency than that of the converter's switching frequency. The amplitude of the external clock pulse must be 3.7 volts or greater and its duration between 15nS to 150nS for sync pulse detection.

The circuit in Figure 2 can be used to produce a 50nS to 150nS pulse from a square wave. The circuit will be turned on by the negative edge of the square wave and will stay on for approximately 50nS (depending on the $R2 \cdot C1$ time constant) (See Figure 3).

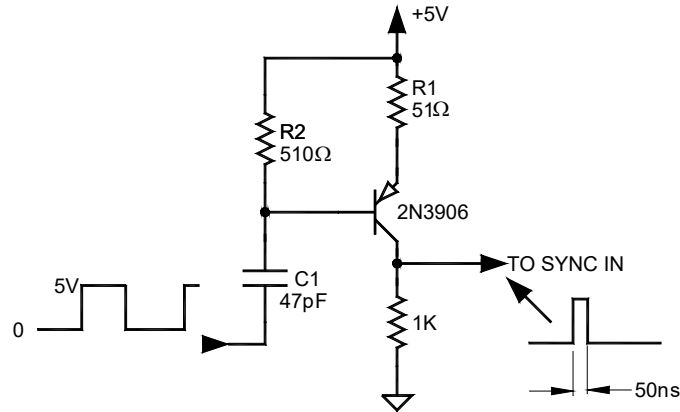

FIGURE 2. 50nS pulse generator from a square wave TTL/5V CMOS clock

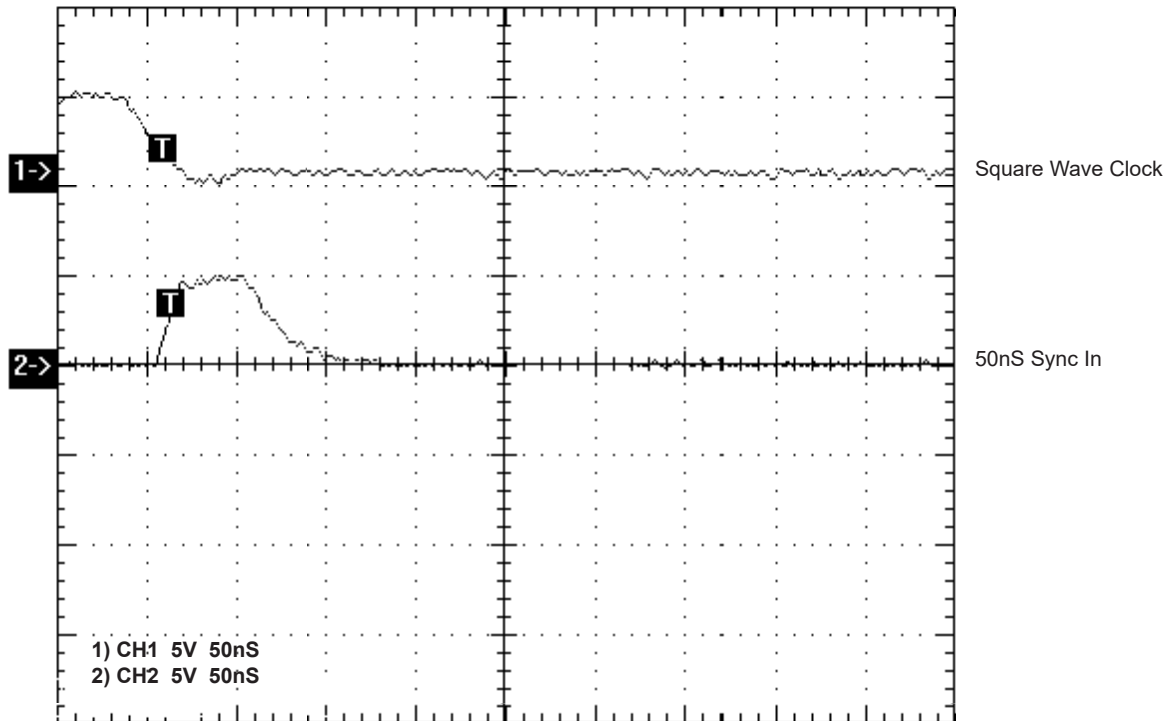

FIGURE 3. Waveforms generated from Figure 2

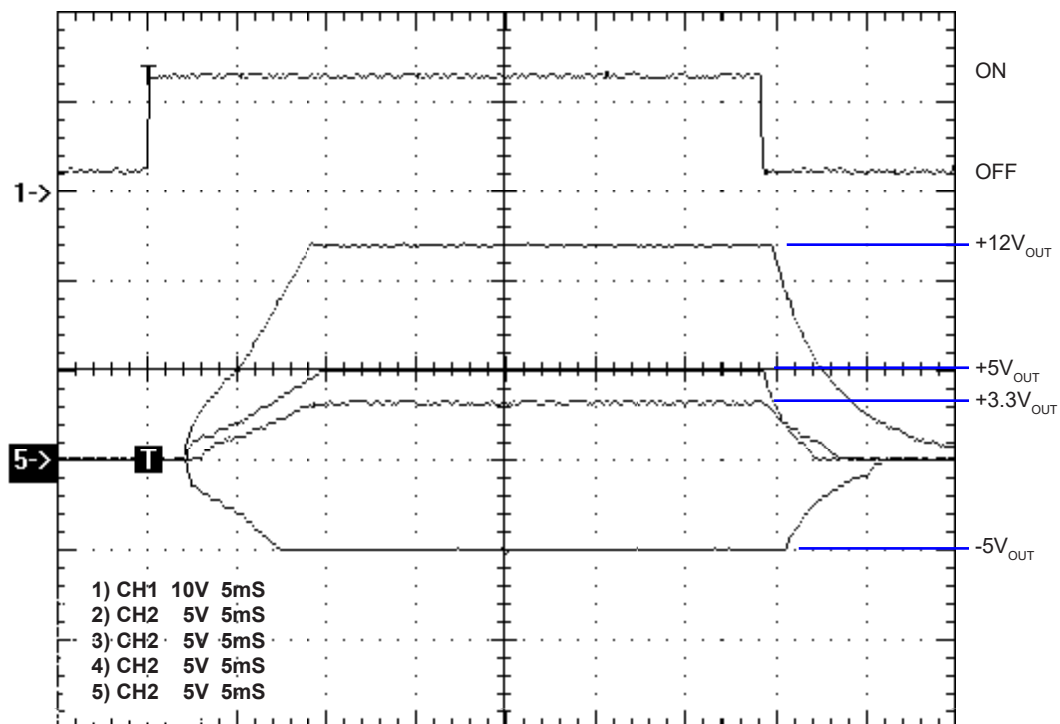
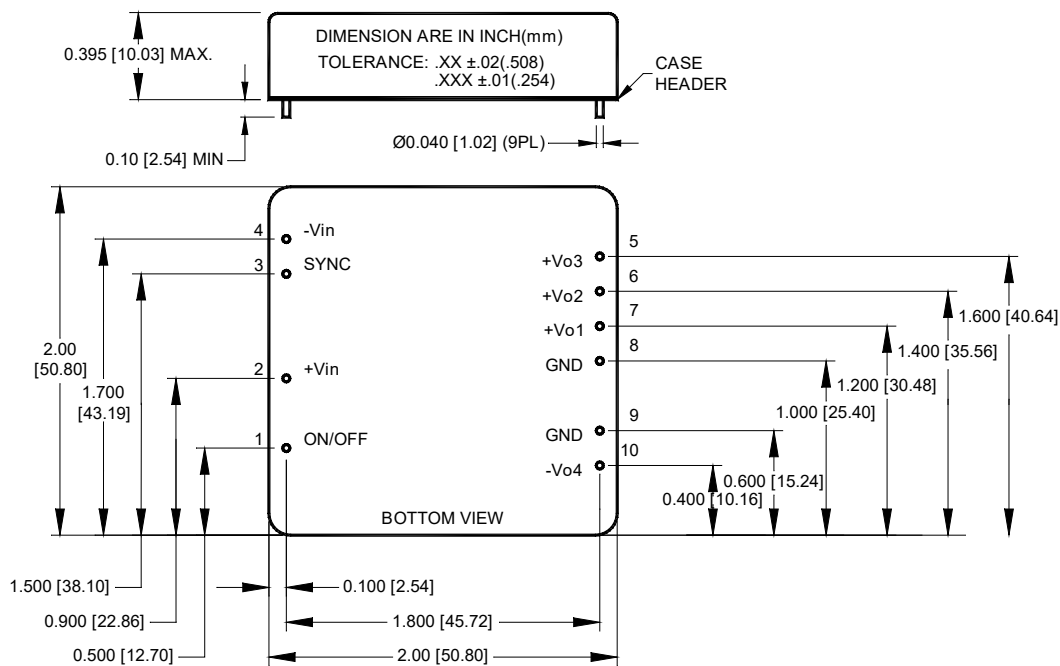

FIGURE 4. Turn on delay and Voltage sequence

MECHANICAL SPECIFICATIONS



Pin	Function
1	ON/OFF (Open = ON)
2	+V _{IN}
3	SYNC
4	-V _{IN}
5	+V _{O3} (12V)
6	+V _{O2} (5V) (MAIN)
7	+V _{O1} (3.3V)
8	GND
9	GND
10	-V _{O4} (-5V)