



# BD15025

## 15W Dual DC/DC Converter

18–60V<sub>IN</sub>  
 +/-12V<sub>OUT</sub>@+/-625mA

### Key Features

- 79% efficiency
- 3:1 input voltage range
- Dual outputs
- Input-to-output isolation
- Soft start
- Short circuit protection
- 150µA off state current
- Multiple converter synchronization



### Functional Description

The BD15025 is a 15W dual DC/DC converter that accepts 18V<sub>IN</sub> to 60V<sub>IN</sub> and provides dual outputs of +/-12V<sub>OUT</sub>@+/-625A. The converter features a 3:1 input voltage range, 400kHz switching frequency, forward topology, -55°C to +85°C operating temperature range, and comes packaged in a 2×1×0.395-inch case. The length of the input/output pins is at least .250 inches.

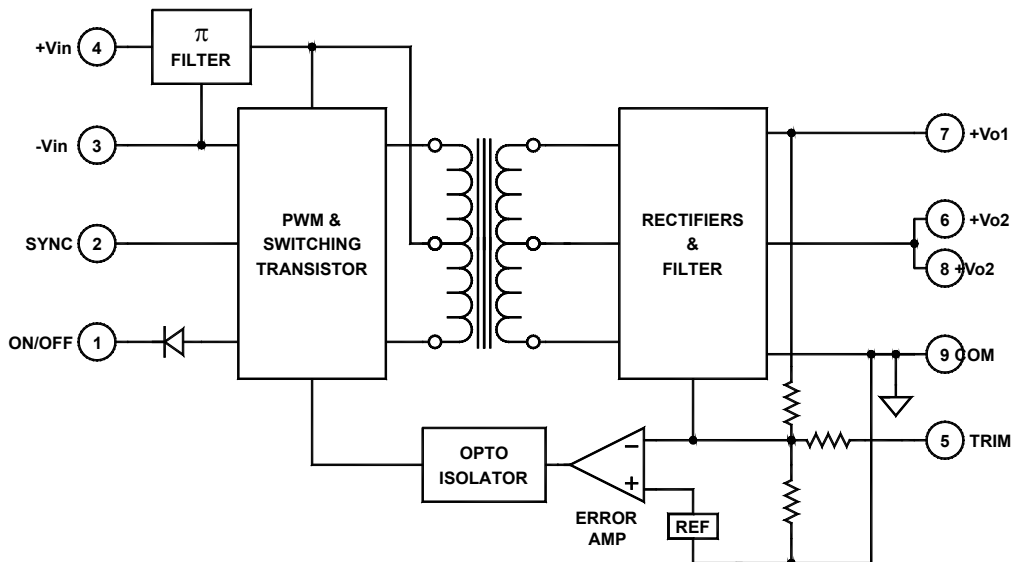

Typical Block Diagram

## Electrical Specifications

### INPUT SPECIFICATIONS

Unless otherwise specified, all parameters are given under typical +25°C with nominal input voltage and under full output load conditions.

PARAMETER	CONDITION / NOTE	MIN	TYP	MAX	UNIT
Input Voltage Range		20	48	60	Vdc
No Load Input Current			20		mA
Full Load Input Current			367		mA
Input Startup Voltage		7			Vdc
Undervoltage Shutdown			8		Vdc
Input Filter	LC				
Reflected Ripple			120		mA
Reverse Polarity	External series-blocking diode				
Input Surge Current (20µS Spike)				10	A
Short Circuit Current Limit			150		% I <sub>IN</sub>
Off State Current			150		µA
Remote ON/OFF Control					
Supply ON	Pin 1 Open (Open circuit voltage: 12V Max.)				

### OUTPUT SPECIFICATIONS

PARAMETER	CONDITION / NOTE	MIN	TYP	MAX	UNIT
Supply Off		0		0.8	Vdc
Output Voltage			±12		Vdc
Output Current			±625		mA
Output Voltage Accuracy			±1	±1.5	%
Output Voltage Adjustment			3	±5	%
Voltage Balance	Balanced loads			±2	
Minimum Load	10% of Full Load				% of FL
Ripple & Noise	peak to peak		1	2	%
Line Regulation	Minimum V <sub>IN</sub> to Maximum V <sub>IN</sub>		±1	±2	%
Load Regulation	Minimum V <sub>IN</sub> to Maximum V <sub>IN</sub> , Outputs Fully Loaded		±1	±2	%
Temperature Coefficient @ FL			0.02		%/°C
Transient Response Time	50% FL to FL to 50% FL		100	150	µS
Short Circuit Protection	All outputs, by input current limiting				

### GENERAL SPECIFICATIONS

PARAMETER	CONDITION / NOTE	MIN	TYP	MAX	UNIT
Efficiency (at full power)			79		%
Isolation Voltage (1 min.), Input to Output	100% Tested in production		1500		Vdc
Isolation Resistance			10 <sup>9</sup>		Ω
Isolation Capacitance			75		pF
Switching Frequency			400		kHz

## ENVIRONMENTAL SPECIFICATIONS

PARAMETER	CONDITION / NOTE	MIN	TYP	MAX	UNIT
Operating Temperature, Industrial		-40		+71	°C
Operating Temperature, Extended		-55		+85	°C
Storage Temperature Range		-55		+125	°C
Thermal Resistance				7.4	°C/W <sub>BISS</sub>
Maximum Operating Case Temperature				100	°C
Derating					
Humidity	Up to 95% non-condensing				
Cooling	Free-air convection				

## PHYSICAL CHARACTERISTICS

PARAMETER	CONDITION / NOTE	MIN	TYP	MAX	UNIT
Dimensions (L×W×H)	2.00×1.00×0.395 in. (50.80×25.40×10.03mm)				
Weight	1.06 oz. (30.3g)				
Case Material	Coated metal				

## EXTERNAL SYNCHRONIZATION

The converter can be synchronized to an external TTL or CMOS clock signal. Insert a 470pF to 1000pF ceramic capacitor between the driving clock signal and the SYNC pin (Pin 2) of the convertor. The frequency of the signal must be between 390kHz

and 430kHz, with a duty cycle of 50% and an amplitude between 3Vdc minimum and 5Vdc typical. See Application Note DC-005: Synchronization.

## EXTERNAL TRIMMING OF OUTPUT VOLTAGES

To trim the output voltage DOWN, connect a 1% 1/8W resistor between the + (plus) output and trim pin of the converter. To trim the output voltage UP, connect a 1% 1/8W resistor between the – (minus) output and trim pins of the converter. For UP/DOWN trimming capability, connect a 10kΩ potentiometer between the + and – output pins, with the wiper arm connected to the trim pin.

The trim resistors/potentiometer can be connected at the converter output pins or the load. However, if connected at the load,

the resistance of the runs becomes part of the feedback network which improves load regulation. If the load is some distance from the converter, the use of #20 gauge wire is recommended to avoid excessive voltage drop due to the resistance of the circuit paths.

See the following application notes:

DC-001: Testing Transient Response in DC/DC Converters

DC-004: Thermal Consideration for DC/DC Converters

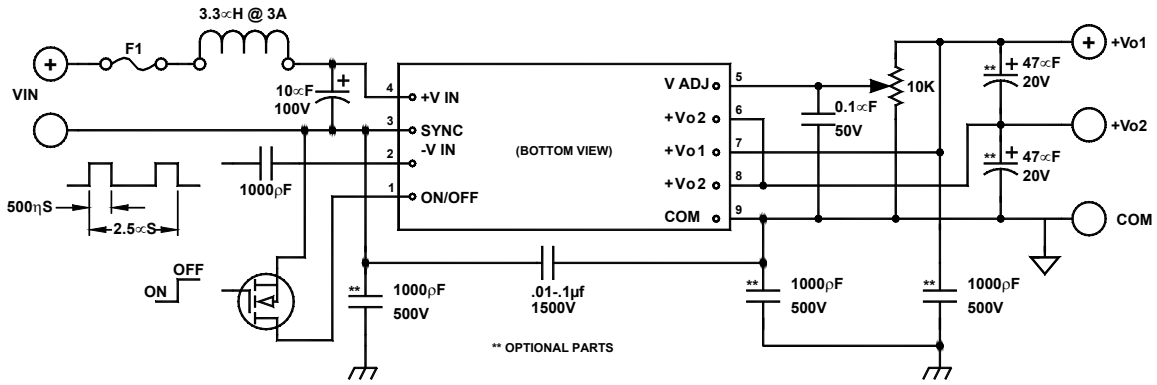
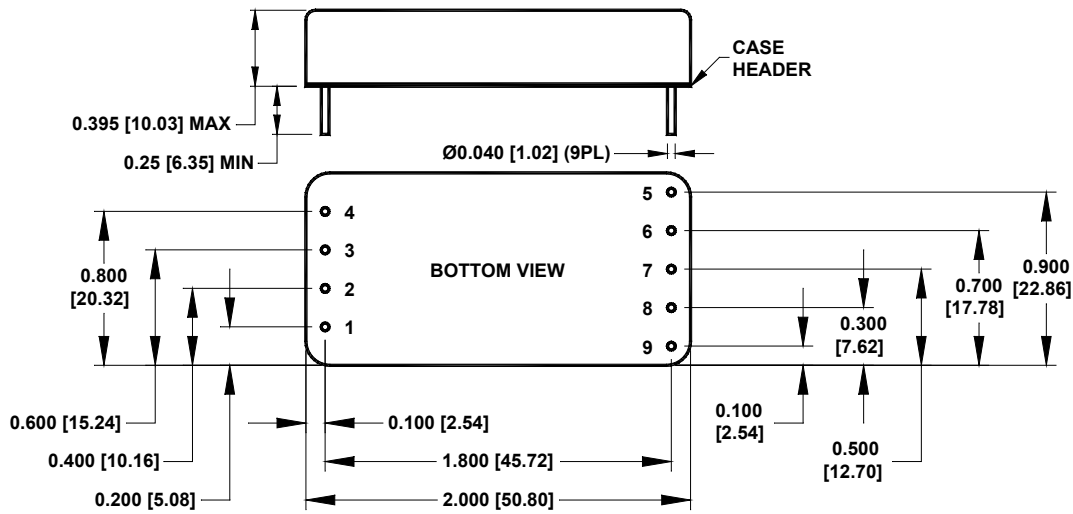

FIGURE 1. Typical connection diagram of BD15025



Pin	Function
1	ON/OFF
2	SYNC
3	-V <sub>IN</sub>
4	+V <sub>IN</sub>
5	V <sub>ADJ</sub>
6	+V <sub>O2</sub>
7	+V <sub>O1</sub>
8	+V <sub>O2</sub>
9	COM (For +V <sub>O1</sub> & +V <sub>O2</sub> )

**MECHANICAL SPECIFICATIONS**  
in inches [mm]