



BD15024

15W Single DC/DC Converter
10-30V Input Voltage Range, 6.5V_{OUT}

With Side Labels & Gold Plated Pins

Key Features

- 3:1 input voltage range
- 82% efficiency
- Input-to-output isolation
- Soft start
- Short circuit protection
- 150µA off state current
- Multiple converter synchronization



Label only shown for illustration purpose only.

Functional Description

The BD15024 is a single DC/DC converter with a 10-30V input voltage range and a 6.5Vdc output. It features a 400kHz switching frequency, forward topology and a 2×1×0.395-inch package size with an industry standard pinout arrangement. Synchronous rectification improves efficiency, while the six-sided shielding, SMD and improved thermal techniques guarantee reliability.

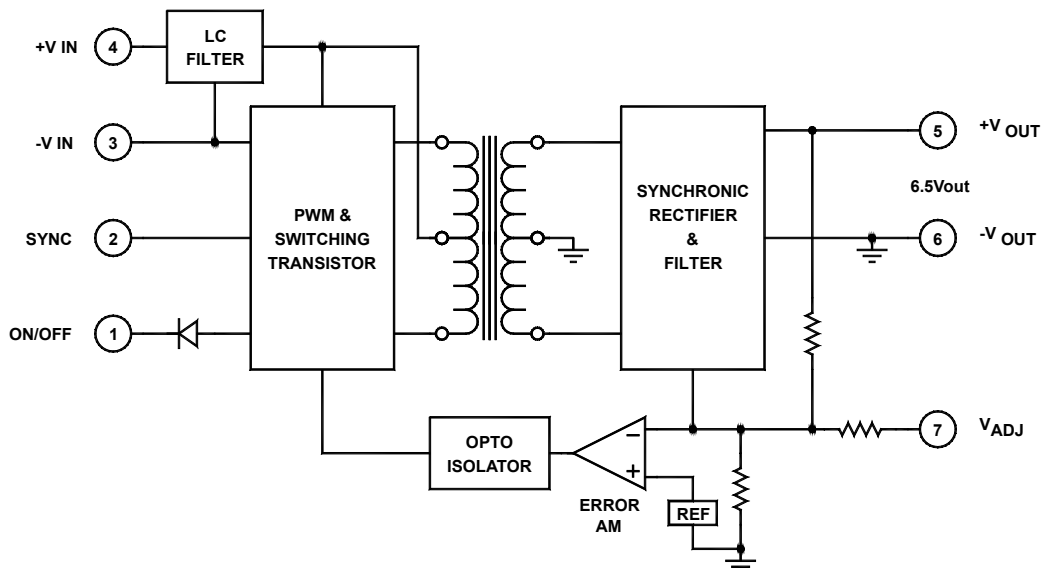

Typical Block Diagram

Unless otherwise specified, all parameters are given under typical +25°C with nominal input voltage and under full output load conditions.

Electrical Specifications

INPUT SPECIFICATIONS

PARAMETER	CONDITION / NOTE	MIN	TYP	MAX	UNIT
Input Voltage Range		10	24	30	Vdc
Input Startup Voltage, 24V _{IN}		7			Vdc
No Load Input Current, 24V _{IN}			140		mA
Full Load Input Current, 24V _{IN}			760		mA
Undervoltage Shutdown			6		Vdc
Input Filter	LC				
Reverse Polarity	External series-blocking diode				
Input Surge Current (20μS Spike)				10	A
Short Circuit Current Limit			150		% I _N Nominal
Off State Current			150		μA
Remote ON/OFF Control					

OUTPUT SPECIFICATIONS

PARAMETER	CONDITION / NOTE	MIN	TYP	MAX	UNIT
Voltage Ratings			6.5		Vdc
Current Ratings			2.3		A
Output Voltage Accuracy			±1		%
Output Voltage Adjustment			5		%
Minimum Load	0% for Single output				% of FL
Ripple & Noise			1	2	%V of V _{PP,OUT}
Line Regulation	Minimum V _{IN} to maximum V _{IN}		±0.5	1	%
Load Regulation	NL to FL		±1		%
Temperature Coefficient @ FL			0.02		%/°C
Transient Response Time	50% FL to FL to 50% FL		100	150	μS

GENERAL SPECIFICATIONS

PARAMETER	CONDITION / NOTE	MIN	TYP	MAX	UNIT
Efficiency (at full power)			82		%
Isolation Voltage (1 min.), Input to Output			1500		Vdc
Isolation Resistance			10 ⁹		Ω
Isolation Capacitance			500		pF

ENVIRONMENTAL SPECIFICATIONS

PARAMETER	CONDITION / NOTE	MIN	TYP	MAX	UNIT
Operating Temperature, Industrial (Ambient)	See Figure 1	-40		+71	°C
Operating Temperature, Extended		-55		+85	°C
Storage Temperature Range		-55		+125	°C
Thermal Resistance				7.4	°C/W _{DISS}
Maximum Operating Case Temperature				100	°C
Derating	See Figure 1				
Humidity	Up to 95% non-condensing				
Cooling	Free-air convection				
EM/RFI	Six-sided continuous shielded metal case				

PHYSICAL CHARACTERISTICS

PARAMETER	CONDITION / NOTE	MIN	TYP	MAX	UNIT
Dimensions (L×W×H)	2.00×1.00×0.395 in. (50.80×25.40×10.03mm)				
Weight	1.06 oz. (30.3g)				
Case Material	Tin Plated Steel				
Pins	Gold Plated				

EXTERNAL SYNCHRONIZATION

The converter can be synchronized to an external TTL or CMOS clock signal. Insert a 470pF to 1000pF ceramic capacitor between the driving clock signal and the SYNC pin (Pin 2) of the

converter. The frequency of the signal must be between 390kHz and 430kHz, with a duty cycle of 50% and an amplitude between 3Vdc minimum and 5Vdc typical. See Application Note DC-005: Synchronization.

EXTERNAL TRIMMING OF OUTPUT VOLTAGES (SINGLE ONLY)

To trim the output voltage DOWN, connect a 5% ¼W resistor between the + (plus) output and trim pin of the converter. To trim the output voltage UP, connect a 5% ¼W resistor between the – (minus) output and trim pins of the converter. For UP/DOWN trimming capability, connect a 10kΩ potentiometer between the + and – output pins, with the wiper arm connected to the trim pin.

the resistance of the runs becomes part of the feedback network which improves load regulation. If the load is some distance from the converter, the use of #20 gauge wire is recommended to avoid excessive voltage drop due to the resistance of the circuit paths.

See our application notes:

- DC-001: Testing Transient Response in DC/DC Converters
- DC-004: Thermal Consideration for DC/DC Converters

TABLE 1. Minimum input operating voltage range for BD15003

BD15003	
% FL	Minimum Input Operating Voltage
	24V_N
10	7.0
25	8.5
50	8.8
75	9.0
100	9.5

