



BD15010A

15W DUAL DC/DC CONVERTER

$36-75V_{IN}$ $\pm 12V_{OUT}$ @ $\pm 625mA$

Key Features

- 2:1 input voltage range
- 85% efficiency
- Input-to-output isolation
- Soft start
- Short circuit protection
- 600 μ A off state current
- Multiple converter synchronization
- Output overvoltage protection (OVP)



Functional Description

The BD15010A is a 15W dual DC/DC converter designed to operate from $36-75V_{IN}$ and provide a dual regulated $\pm 12V_{OUT}$ @ $625mA$. Six-sided shielding, SMD and improved thermal techniques guarantee reliability.

NOTE: Case is connected to $-V_{IN}$

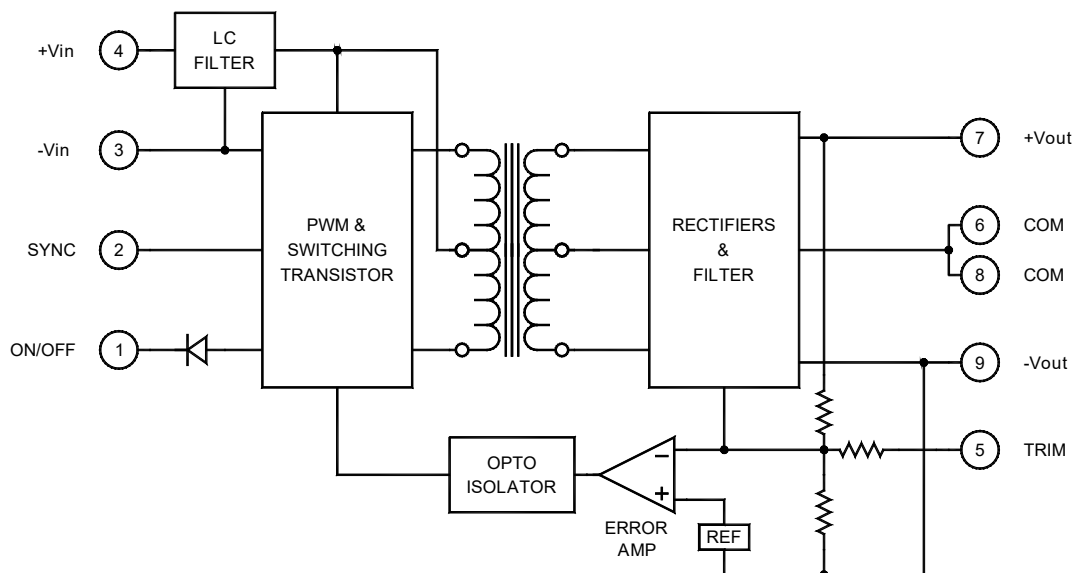

Typical Block Diagram

Electrical Specifications

INPUT SPECIFICATIONS

Unless otherwise specified, all parameters are given under typical +25°C with nominal input voltage and under full output load conditions.

PARAMETER	CONDITION / NOTE	MIN	TYP	MAX	UNIT
Input Voltage Range		36	48	75	Vdc
Input Startup Voltage		15			Vdc
Input Filter	LC				
Reverse Polarity	External series-blocking diode				
No Load Input Current			10		mA
Full Load Input Current			367		mA
Input Reflected Ripple			120		mA _{PP}
Input Surge Current (20µS Spike)				10	A
Short Circuit Current Limit			150		% I _{IN}
Off State Current			600		µA
Remote ON/OFF Control					
Supply ON	Pin 1 Open (Open circuit voltage: 12V Max.)				
Supply OFF		0		0.8	Vdc
Logic Input Reference	-Input for ON/OFF and SYNC				
Logic Compatibility	TTL Open Collector or CMOS Open Drain				

OUTPUT SPECIFICATIONS

PARAMETER	CONDITION / NOTE	MIN	TYP	MAX	UNIT
Output Voltage			±12		Vdc
Output Voltage Accuracy			±1		%
Output Current			±625		mA
Output Voltage Adjustment	Referenced to -V _{OUT}		5		%
Voltage Balance, Dual	Balanced loads			±2	%
Minimum Load			10		% of FL
Ripple & Noise			1	2	%V _{PP} of V _{OUT}
Line Regulation, Dual	Minimum V _{IN} to maximum V _{IN}		±1	2	%
Load Regulation, Dual	See Figure 5 for isolated output		±1		%
Temperature Coefficient @ FL			0.02		%/°C
Transient Response Time	50% FL to FL to 50% FL		100	150	µS
Short Circuit Protection	All outputs, by input current limiting				
Turn On Delay with Soft Start			2		mS
Output Overvoltage Protection			130	150	% of V _{OUT}

GENERAL SPECIFICATIONS

PARAMETER	CONDITION / NOTE	MIN	TYP	MAX	UNIT
Efficiency (at full power)			85		%
Isolation Voltage (1 min.), Input to Output			1500		Vdc
Isolation Voltage, Output to Output			500		Vdc
Isolation Resistance			10 ⁹		Ω
Isolation Capacitance			500		pF
Switching Frequency			300		kHz

ENVIRONMENTAL SPECIFICATIONS

PARAMETER	CONDITION / NOTE	MIN	TYP	MAX	UNIT
Operating Temperature, Industrial (Ambient) ²	See Figure 1	-40		+71	°C
Storage Temperature Range		-55		+125	°C
Thermal Resistance				7.4	°C/W _{DISS}
Maximum Operating Case Temperature				100	°C
Derating	See Figure 1				
Humidity	Up to 95% non-condensing				
Cooling	Free-air convection				
EMI/RFI	Six-sided continuous shielded metal case				
MTBF	per MIL-HNBK-217F (Ground benign, +25°C)		1.1×10 ⁶		hours

PHYSICAL CHARACTERISTICS

PARAMETER	CONDITION / NOTE	MIN	TYP	MAX	UNIT
Dimensions (L×W×H)	2.00×1.00×0.395 in. (50.80×25.40×10.03mm)				
Weight	1.06 oz. (30.3g)				
Case Material	Coated metal				
Shielding Connection, 48V _{IN}	-Input Ground (Pin 3)				

¹ Measured with 10µF capacitor at the input power pins.

² Maximum output current must not exceed 1 amp at either output.

EXTERNAL SYNCHRONIZATION

The converter can be synchronized to an external TTL or CMOS clock signal. Insert a 100pF ceramic capacitor between the driving clock signal and the SYNC pin (Pin 2) of the converter. The

frequency of the signal must be between 320kHz and 360kHz, with a duty cycle of 50% and an amplitude between 3Vdc minimum and 5Vdc typical. See Application Note DC-005: Synchronization.

EXTERNAL TRIMMING OF OUTPUT VOLTAGES (SINGLE AND DUAL ONLY) (SEE FIGURE 3)

To trim the output voltage DOWN, connect a 1% 1/8W resistor between the + (positive) output and trim pin of the converter. To trim the output voltage UP, connect a 1% 1/8W resistor between the – (negative) output and trim pins of the converter. For UP/DOWN trimming capability, connect a 10kΩ potentiometer between the + and – output pins, with the wiper arm connected to the trim pin.

The trim resistors/potentiometer can be connected at the converter output pins or the load. However, if connected at the load,

the resistance of the runs becomes part of the feedback network which improves load regulation. If the load is some distance from the converter, the use of #20 gauge wire is recommended to avoid excessive voltage drop due to the resistance of the circuit paths.

See our application notes:

DC-001: Testing Transient Response in DC/DC Converters

DC-004: Thermal Consideration for DC/DC Converters

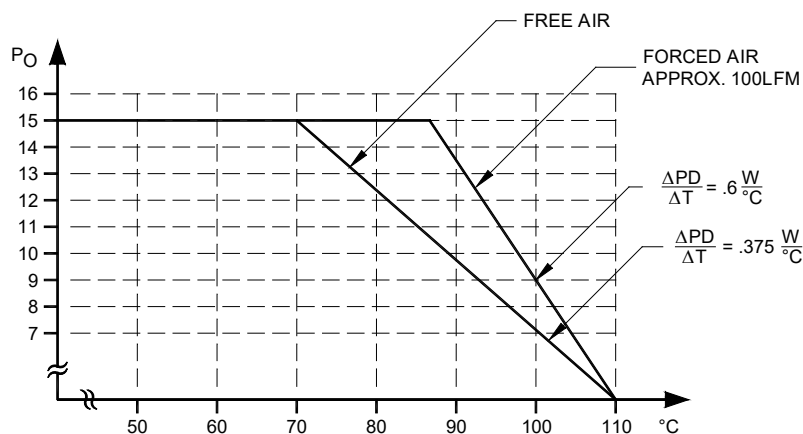

FIGURE 1. Worst case derating of 15W series

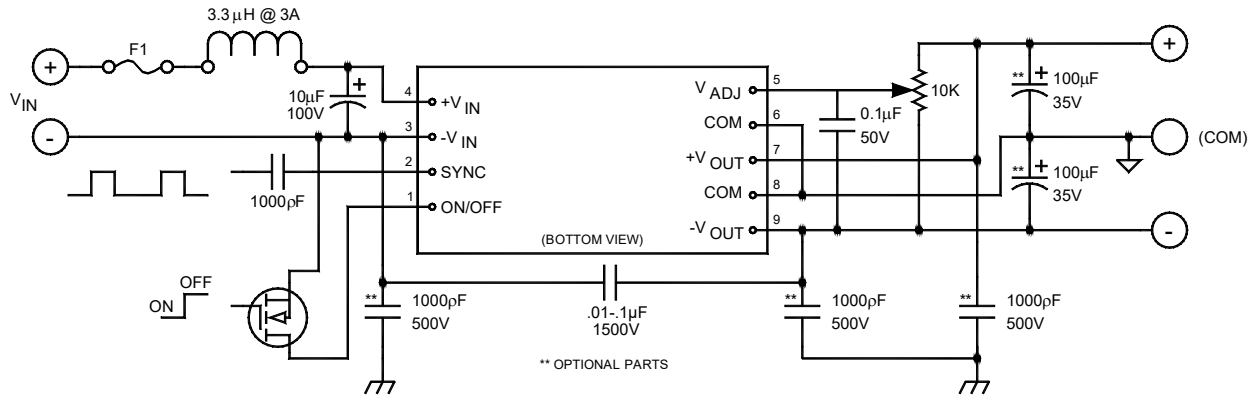

FIGURE 2. Typical connection diagram

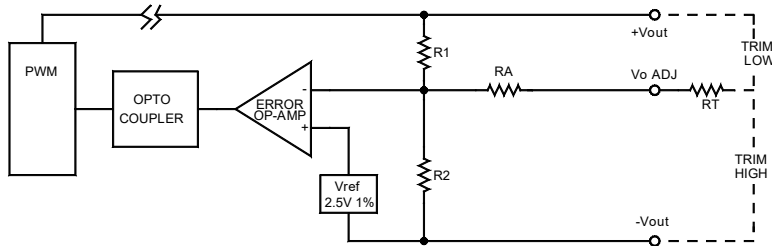

FIGURE 3. Output control circuit

To trim V_o higher to V_o' , where V_o is the actual measured value:

$$RT = \frac{R1 \cdot V_{REF}}{V_o' - V_o}$$

To trim V_o lower to V_o'' , where V_o is the actual measured value:

$$RT = \left[\left(\frac{R_1 \cdot V_{REF}}{R_2(V_o - V_o'')} - R1 \right) RA \right]$$

Resistor	Value (K)
R1	21.5
R2	2.49
RA	20

MECHANICAL SPECIFICATIONS

in inches [mm]

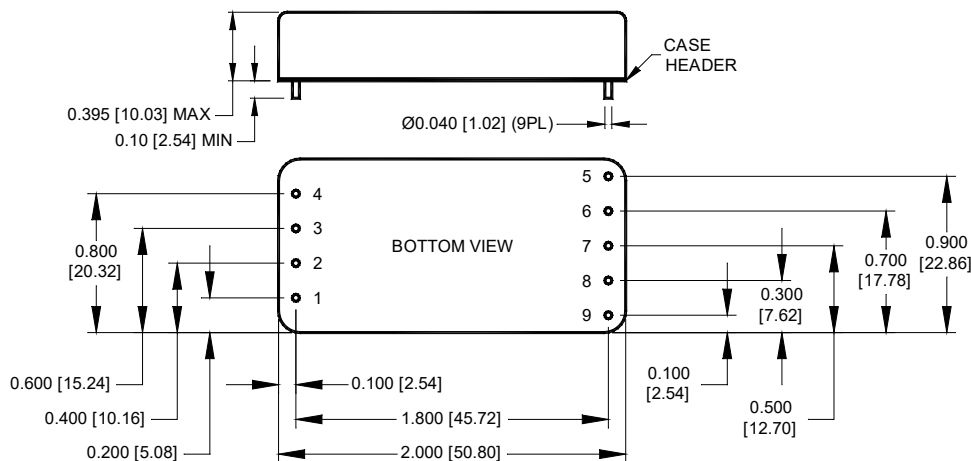

Pin	Function
1	ON/OFF
2	SYNC
3	-V _{IN}
4	+V _{IN}
5	V _{ADJ}
6	OUTPUT COM
7	+OUTPUT
8	OUTPUT COM
9	-OUTPUT