



BD15008A

20W DUAL DC/DC CONVERTER

$36-75V_{IN}$, $\pm 7V_{OUT}@1.43A$

Key Features

- 2:1 input voltage range
- 80% efficiency
- Input-to-output isolation
- Soft start
- Short circuit protection
- 150 μ A off state current
- Multiple converter synchronization
- Dual isolated outputs
- Output overvoltage protection (OVP)



Functional Description

The BD15008A is a 20W dual DC/DC converter that accepts $36-75V_{IN}$ and produces $\pm 7V_{OUT}@1.43A$. The converter offers 2:1 input voltage range, 300kHz switching frequency, forward topology and comes packaged in a $2 \times 1 \times 0.395$ -inch case. The converter is designed and tested for 1500Vdc input-to-output isolation and will synchronize to an external clock frequency of 310kHz or higher.

Note: Case is connected to $-V_{in}$

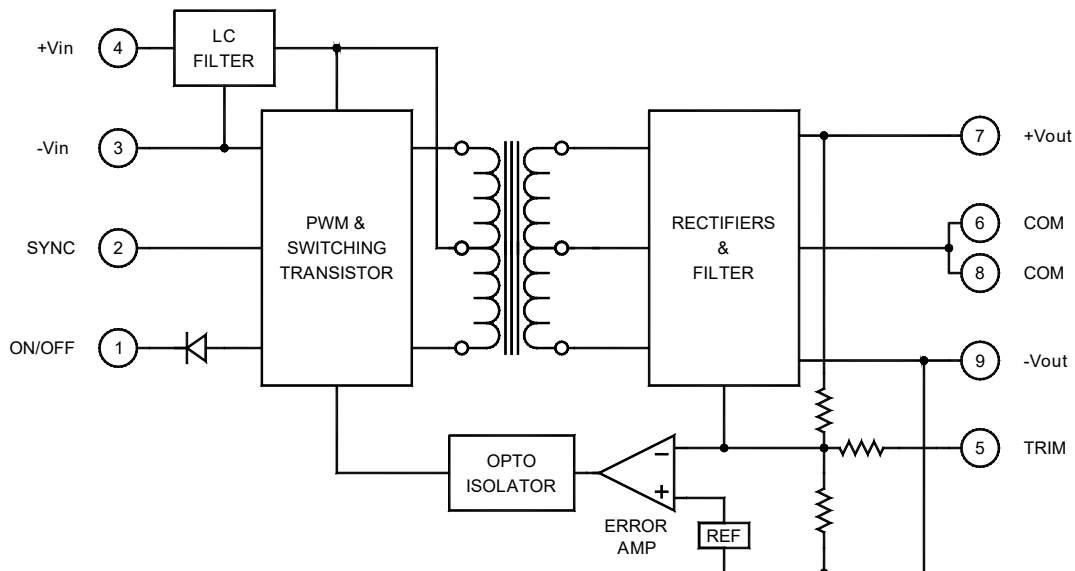

Typical Block Diagram

Electrical Specifications

INPUT SPECIFICATIONS

Unless otherwise specified, all parameters are given under typical +25°C with nominal input voltage and under full output load conditions.

PARAMETER	CONDITION / NOTE	MIN	TYP	MAX	UNIT
Input Voltage Range		36	48	75	Vdc
No Load Input Current			10		mA
Full Load Input Current			508		mA
Input Startup Voltage		12			Vdc
Input Filter	LC				
Reflected Ripple	C 10 μ F		120		mA
Reverse Polarity	External series-blocking diode				
Input Surge Current (20 μ S Spike)				10	A
Short Circuit Current Limit			150		% I _{IN}
Off State Current			150		μ A
Remote ON/OFF Control					
Supply ON	Pin 1 Open (Open circuit voltage: 12V Max.)				
Supply OFF		0		0.8	Vdc
Logic Input Reference	-Input for ON/OFF and SYNC				
Logic Compatibility	TTL Open Collector or CMOS Open Drain				
Sync Frequency	Amplitude of 3.3V to 5V	310	340	360	kHz

OUTPUT SPECIFICATIONS

PARAMETER	CONDITION / NOTE	MIN	TYP	MAX	UNIT
Output Voltage			\pm 7		Vdc
Output Voltage Accuracy			\pm 1		%
Output Voltage Adjustment			5		%
Voltage Balance	Balanced loads			\pm 2	%
Output Current			\pm 1430		mA
Minimum Load	0% for Single output, 10% for all other models				% of FL
Ripple & Noise			1	2	%V _{PP} of V _{OUT}
Line Regulation	With balanced loads		3	\pm 5	%
Load Regulation*			\pm 1		%
Temperature Coefficient @ FL			0.02		%/°C
Transient Response Time	50% FL to FL to 50% FL		100	150	μ S
Short Circuit Protection	All outputs, by input current limiting				
Turn On Delay with Soft Start			2		mS
Output Overvoltage Protection			130	150	% of V _{OUT}

* Maximum output current must not exceed 2 amps at either output.

GENERAL SPECIFICATIONS

PARAMETER	CONDITION / NOTE	MIN	TYP	MAX	UNIT
Efficiency (at full power)			80		%
Isolation Voltage (1 min.), Input to Output	100% Tested in production		1500		Vdc
Isolation Resistance			10 ⁹		Ω
Isolation Capacitance			75		pF
Switching Frequency			300		kHz

ENVIRONMENTAL SPECIFICATIONS

PARAMETER	CONDITION / NOTE	MIN	TYP	MAX	UNIT
Operating Temperature, Industrial (Ambient) ²	See Figure 2	-40		+71	°C
Storage Temperature Range		-55		+125	°C
Thermal Resistance				7.4	°C/W _{DISS}
Maximum Operating Case Temperature				100	°C
Derating	See Figure 2				
Humidity	Up to 95% non-condensing				
Cooling	Free-air convection				
EMI/RFI	Six-sided continuous shielded metal case				
MTBF	per MIL-HNBK-217F (Ground benign, +25°C)		1.1×10 ⁶		hours

PHYSICAL CHARACTERISTICS

PARAMETER	CONDITION / NOTE	MIN	TYP	MAX	UNIT
Dimensions (L×W×H)	2.00×1.00×0.395 in. (50.80×25.40×10.03mm)				
Weight	1.06 oz. (30.3g)				
Case Material	Coated metal				
Shielding Connection	-Input Ground (Pin 3)				

EXTERNAL SYNCHRONIZATION

The converter can be synchronized to an external TTL or CMOS clock signal. Insert a 1000pF ceramic capacitor between the driving clock signal and the SYNC pin (Pin 2) of the converter. The

frequency of the signal must be between 310kHz and 360kHz, with a duty cycle of 50% and an amplitude between 3Vdc minimum and 5Vdc typical. See Application Note DC-005: Synchronization.

EXTERNAL TRIMMING OF OUTPUT VOLTAGES

To trim the output voltage DOWN, connect a 1% 1/8W resistor between the + (positive) output and trim pin of the converter. To trim the output voltage UP, connect a 1% 1/8W resistor between the - (negative) output and trim pins of the converter. For UP/DOWN trimming capability, connect a 10kΩ potentiometer between the + and - output pins, with the wiper arm connected to the trim pin.

The trim resistors/potentiometer can be connected at the converter output pins or the load. However, if connected at the load,

the resistance of the runs becomes part of the feedback network which improves load regulation. If the load is some distance from the converter, the use of #20 gauge wire is recommended to avoid excessive voltage drop due to the resistance of the circuit paths.

See the following application notes:

DC-001: Testing Transient Response in DC/DC Converters
DC-004: Thermal Consideration for DC/DC Converters

TABLE 1. Minimum input operating voltage range

% FL	Minimum Input Operating Voltage
	24V _{IN}
10	7.0
25	8.5
50	8.8
75	9.0
100	9.5

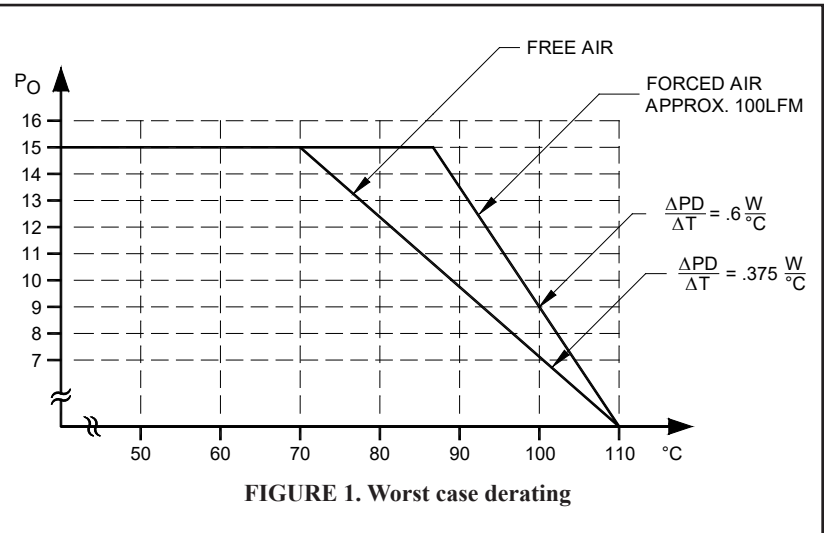

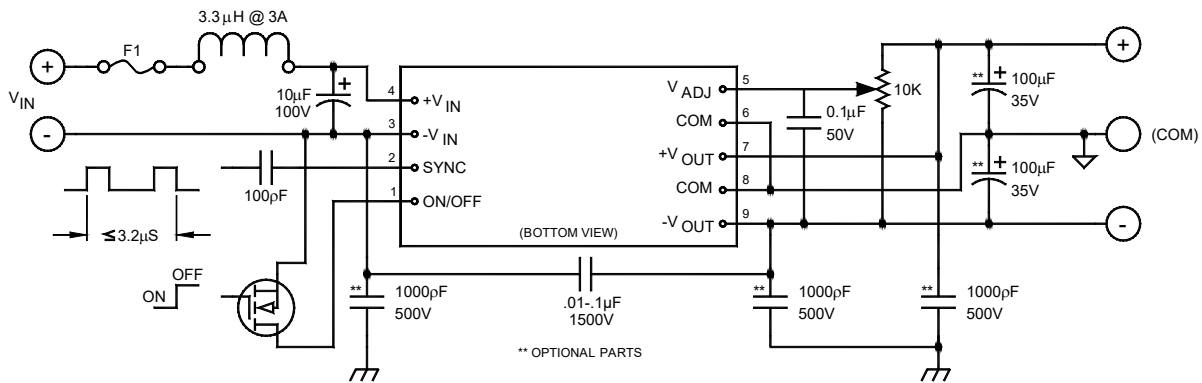

FIGURE 2. Typical connection diagram

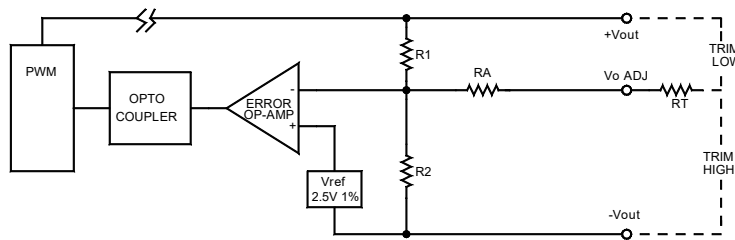

FIGURE 3. Output control circuit

To trim V_o higher to V_o' , where V_o is the actual measured value:

$$RT = \frac{R1 \cdot V_{REF}}{V_o' - V_o}$$

To trim V_o lower to V_o'' , where V_o is the actual measured value:

$$RT = \left[\left(\frac{R_1^2 \cdot V_{REF}}{R_2 \cdot (V_o - V_o'')} \right) - R1 \right] - RA$$

Resistor	Value (K)
R1	15
R2	3.24
RA	12

MECHANICAL SPECIFICATIONS

in inches [mm]

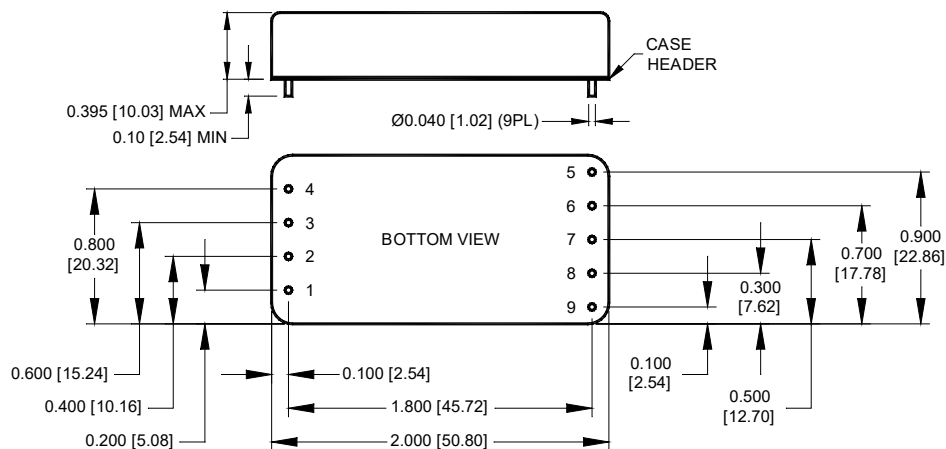

Pin	Function
1	ON/OFF
2	SYNC
3	-V _{IN}
4	+V _{IN}
5	V _{ADJ}
6	GND
7	+OUTPUT
8	GND
9	-OUTPUT